Bushings

Featuring: Center Bonded Bushings
Square Bonded Bushings



Center Bonded Bushings and Square Bonded Bushings are used in applications where the absorption shock, attenuation of noise, reduction of wear and elimination of lubrication is required.

Center Bonded Bushings are designed to be loaded radially and utilize a soft torsional spring rate to provide freedom in rotation. High radial restraint maintains the alignment between joined parts. They are not intended for use where extreme rotational motion will occur. Typical applications include heavy duty highway equipment, drilling equipment, harvesters, combines and industrial machinery.

Square Center Bonded Bushings accommodate angular movement and isolate vibratory disturbances in heavy equipment. These bushings combine a torsional spring with an elastomeric pivot and isolator. They provide positive torsional positioning and pivot action under the most demanding operating conditions. Typical applications include wheel suspensions, vibratory feeders, mobile power equipment and vibratory cable layers.

Easy to install, the uncomplicated designs of the Center Bonded and Square Bonded Bushings provide initial economy, while the rugged elastomers and high strength bonding assure extended service life.

Features and Benefits:

- Easy to install.
- Uncomplicated design provides initial economy.
- High-strength bonding assures extended service life.
- Minimal maintenance due to specially compounded elastomer.

Bushings

Center Bonded Bushings With Outer Member

Specifications and Dimensions: Table 1.

Part Number	Maximum Radial Static Load Rating		Spring Rate Radial (K rad)		Torsional		Recommended Socket Dimensions			
							Diameter		Length	
	lbs	N	lbs/in	N/mm	lbs-in/deg	N-mm/deg	in ± .001	mm	in	mm
J-3830-13	300	1334	14,000	2451	3.6	0.6	1.245	31.6	.88	22.35
J-5385-31	1000	4448	36,600	6408	18.7	3.3	1.743	44.3	2.00	50.80
J-6729-2	6000	26,689	150,000	26,265	119	20.8	1.996	50.7	4.00	101.60
J-6740-3	9300	41,368	256,000	44,825	475	83.2	3.231	82.1	4.00	101.60

Center Bonded Bushings Without Outer Member

Specifications and Dimensions: Table 2.

Part Number	Maximum Radial Static Load Rating		Spring Rate Radial (K rad)		Torsional		Recommended Socket Dimensions			
							Diameter Ø		Length	
	lbs	N	lbs/in	N/mm	lbs-in-deg	N/mm-deg	in	mm	in	mm
J-3830-6	200	890	13,700	2398	4.8	0.8	1.06	27.05	.88	22.35
J-2005-2†	250	1112	14,800	2591	3.0	0.5	.70	17.78	1.00	25.40
J-4705-2	625	2780	25,200	4412	16	2.8	1.28	32.63	1.44	36.58
J-6424-1	780	3470	39,200	6863	23	4.0	1.37	34.92	1.47	37.34
J-6310-1	925	4115	27,500	4815	25	4.4	1.72	44.68	1.56	39.62
J-5385-32	1000	4448	26,200	4587	24	4.2	1.58	40.25	2.12	53.85
J-5950	1125	5004	40,000	7004	94	16.5	2.22	56.38	1.88	47.75
J-5506	1800	8007	24,600	4307	58	10.2	2.75	69.85	2.25	57.15
J-7121-2	1950	8674	105,000	18,385	100	17.5	1.75	44.45	2.75	69.85
J-7231-1	2075	9230	168,000	29,416	81	14.2	2.44	61.97	1.81	45.97
J-5807-1	2700	12,010	96,000	16,809	105	18.4	2.31	58.67	3.00	76.20
J-5971	3200	14,234	102,000	17,860	260	45.5	3.70	93.98	2.25	57.15
J-6729	5250	23,353	164,000	28,716	123	21.5	1.75	44.45	4.00	101.60
J-6145	8200	36,475	312,000	54,631	796	139.4	4.00	101.60	4.00	101.60

⊖ Tolerance ± .015 (± .38 mm) for joints without outer member.

† Non-Stock Item, please contact Lord Corporation for availability.

For installation instructions, see P. 80.

First determine the amount of static loading at the installation point. Then determine the conditions under which the joint will operate. The following should be used as a guide to part selection for Type "A" and Type "B" service.

TYPE A: Extreme conditions (reversing dynamic load or distortion at high frequency — over 600 cpm) use 1/3 the Radial Static Load Rating.

TYPE B: Average conditions (constant radial load, intermittent shock) use the Radial Static Load Rating.

Center Bonded Bushings With Outer Member

Specifications and Dimensions: Table 3.

Part Number	Part Dimensions							
	A		B		C		D	
	in	mm	in	mm	in	mm	in	mm
J-3830-13	.516	13.1	1.253	31.8	1.00	25.4	.75	19.1
J-5385-31	.504	12.8	1.750	44.5	2.62	66.5	1.00	25.4
J-6729-2	1.129	28.7	2.004	50.9	4.25	108.0	1.31	33.3
J-6740-3	1.500	38.1	3.234	82.1	7.50	190.5	2.12	53.8

Center Bonded Bushings Without Outer Member

Specifications and Dimensions: Table 4.

Part Number	Part Dimensions							
	A		B		C		D	
	in	mm	in	mm	in	mm	in	mm
J-3830-6	.517	13.1	1.12	28.4	1.00	25.4	.75	19.1
J-2005-2†	.315	8.0	.75	19.1	1.06	26.9	.44	11.2
J-4705-2	.641	16.3	1.37	34.8	1.63	41.4	.88	22.4
J-6424-1	.627	15.9	1.45	36.8	1.53	38.9	1.00	25.4
J-6310-1	1.004	25.5	1.84	46.7	1.69	42.9	1.25	31.8
J-5385-32	.504	12.8	1.75	44.5	2.62	66.5	1.00	25.4
J-5950	1.316	33.4	2.39	60.7	2.24	56.9	1.50	38.1
J-5506	1.360	34.5	2.97	75.4	2.75	69.9	2.00	50.8
J-7121-2	1.003	25.5	1.94	49.3	2.99	75.9	1.19	30.2
J-7231-1	1.457	36.9	2.63	66.8	1.94	49.3	2.00	50.8
J-5807-1	1.251	31.8	2.47	62.7	3.37	85.6	1.62	41.1
J-5971	1.503	38.2	3.93	99.8	2.50	63.5	3.00	76.2
J-6729	1.129	28.7	1.86	47.2	4.25	108.0	1.31	33.3
J-6145	2.008	51.0	4.19	106.4	6.00	152.4	3.25	82.6

† Non-Stock Item, please contact Lord Corporation for availability.

Part Dimension (With outer member)

Figure 1

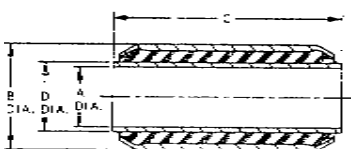

Part Dimension (Without outer member)

Figure 2

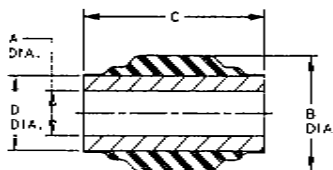

Installation View

Figure 3

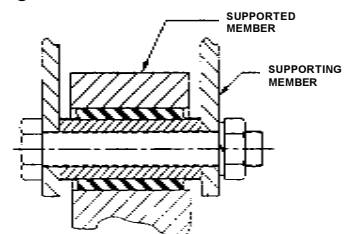

Bushings

Square Bonded Bushings

Specifications and Dimensions: Table 1.

Part Number	Maximum Radial Static Load Rating		Radial Spring Rate (K rad)		Static Torque @ 15 Degrees ϕ		Key Location	Part Dimensions					
								A		B		C	
	lbs	N	lbs/in	N/mm	lbs.-in.	N-mm		in	mm	in	mm	in	mm
J-6450-19†	700	3114	25,000	4378	400	542	Y	1.75	44.5	2.62	66.5	.626	15.9
J-8203-1	1300	5783	40,000	7004	1000	1355	Y	2.38	60.5	3.25	82.6	1.379	35.0
J-8203-19†	1700	7562	60,000	10,506	1500	2033	Y	2.38	60.5	3.25	82.6	1.379	35.0
J-8203-31†	1000	4448	30,000	5253	750	1016	Y	2.38	60.5	3.25	82.6	1.379	35.0
J-8203-35†	1700	7562	100,000	17,510	2400	3252	Y	2.40	61.0	3.25	82.6	1.379	35.0
J-9832-8†	2500	11,121	70,000	12,257	2700	3659	X	3.40	86.4	4.00	101.6	2.009	51.0
J-9832-11	5000	22,241	160,000	28,016	5200	7046	X	3.42	86.9	4.00	101.6	2.009	51.0

ϕ Rated static angular deflection is 15° for all parts. Maximum recommended deflection, static plus dynamic is 45° for all parts. Heavy wall tubing is recommended for proper operation.

For installation instructions, see P. 80.

† Non-Stock Item, please contact Lord Corporation for availability.

Square Bonded Bushings

Specifications and Dimensions: Table 2.

Part Number	Part Dimensions													
	D		E		F		G		H		I		J	
	in	mm	in	mm	in	mm	in	mm	in	mm	in	mm	in	mm
J-6450-19†	1.00	25.4	1.17	29.7	1.62	41.1	1.75	44.5	.191	4.9	.719	18.3	.09	2.3
J-8203-1	1.62	41.1	2.15	54.6	2.25	57.2	3.00	76.2	.191	4.9	1.444	36.7	.09	2.3
J-8203-19†	1.62	41.1	2.15	54.6	2.25	57.2	3.00	76.2	.191	4.9	1.444	36.7	.09	2.3
J-8203-31†	1.62	41.1	2.15	54.6	2.25	57.2	3.00	76.2	.191	4.9	1.444	36.7	.09	2.3
J-8203-35†	1.62	41.1	2.15	54.6	2.25	57.2	3.00	76.2	.191	4.9	1.442	36.7	.09	2.3
J-9832-8†	2.53	64.3	2.50	63.5	3.25	82.6	3.75	95.3	.253	6.4	2.128	54.1	.09	2.3
J-9832-11	2.53	64.3	2.50	63.5	3.25	82.6	3.75	95.3	.253	6.4	2.128	54.1	.09	2.3

† Non-Stock Item, please contact Lord Corporation for availability.

To select a Square Bonded Bushing for your requirements, compute the static torsional load it must support. Select from Tables 1-2, a bushing with static torque at 15° which is equal to or greater than the computed load.

Compute the static plus the dynamic torsional load. If this total load exceeds three times the static torque at 15°, select a larger size static torque rating part. Static radial load should also be computed and compared to the maximum static radial load listed above. Dynamic plus static radial load can also be three times loads listed above.

Part Dimension

Figure 1

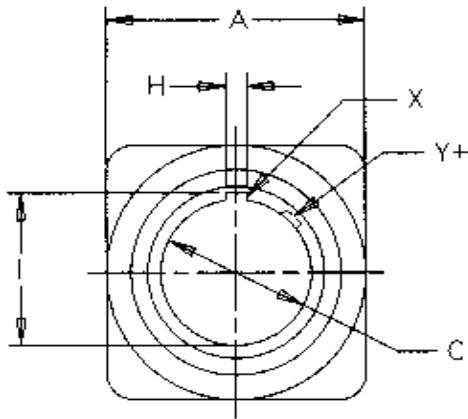

+Y - KEY LOCATION 45° FROM VERTICAL

Installation Socket

Figure 2

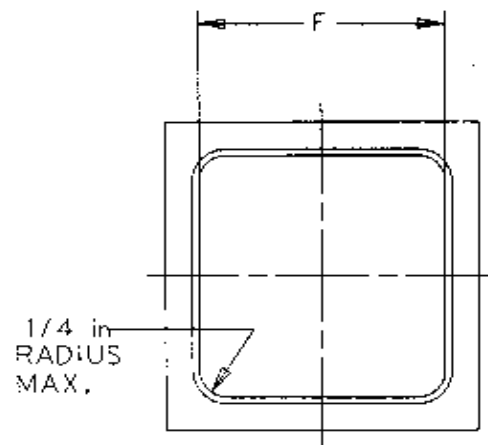
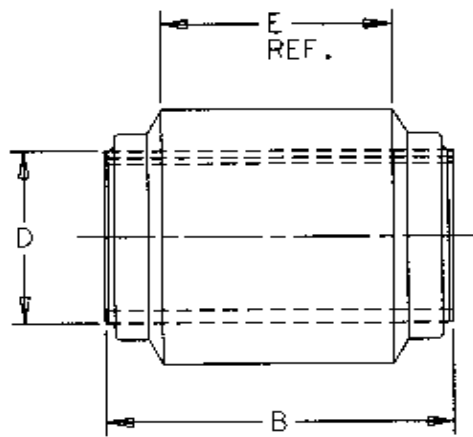
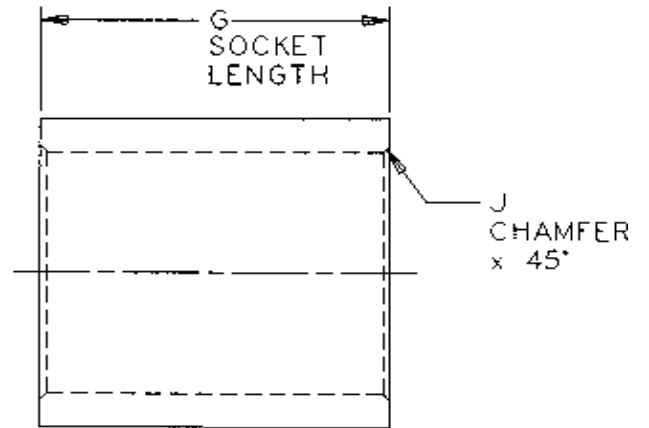

Bushings

Installation Guide

Installation:

Joint With Outer Sleeve: Clamp or press-fit the outer sleeve into a socket which has been machined to the dimensions shown on Table 1. The force required to install the joint in the socket with a press-fit can be approximated from the formula:

$$\text{Force (lbs.)} = 2500 \times \text{diameter} \times \text{length}$$

The inner member is normally attached by clamping or bolting its extended ends to a mounting bracket. An alternate method would be to press-fit a shaft through the inner tube.

Joint Without Outer Sleeve: Since the outer part of this type joint is the flexing element, it must be compressed and inserted directly into a socket which has been machined to the dimensions shown on Table 2. This is done with the aid of a funnel-shaped fixture and a suitable lubricant: P-80 Rubber Emulsion Lubricant made by International Products Corporation, P. O. Box 70, Burlington, NJ 08016-0070, Phone: (609) 386-8770, FAX: (609) 386-8438.

The inner member attachment is accomplished in the same manner as described above for the joint with outer sleeve.

Suggested Funnel Design

Figure 4

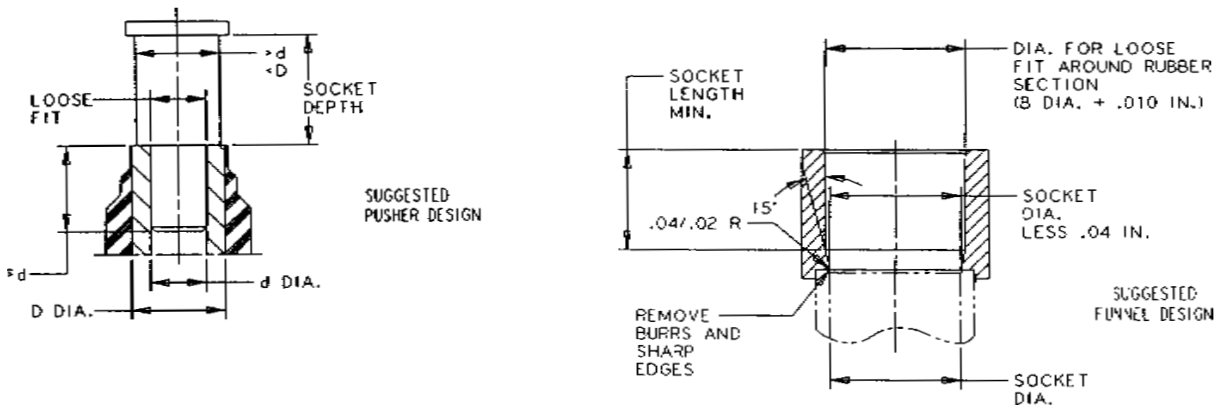

Installation: Square Bonded Bushings

Joints may be installed in preformed sockets machined, cast or fabricated to dimensions as shown in Table 1.

Installation is a simple, four-step procedure:

1. Lubricate the mount and socket lightly with P-80 Rubber Emulsion Lubricant or water. Lubricant available from International Products Corporation, P. O. Box 70, Burlington, NJ 08016-0070, Phone: (609) 386-8770, FAX: (609) 386-8438.
2. Insert assembly fixture or driving bolt through center member. Take care that driving members do not overhang center member outside diameter or damage may result to the elastomer.
3. Apply sufficient pressure to seat the joint in the center of the supporting socket.
4. Attach the supported member snug against the center member.